



# FiberLyte PWM Userguide

## Product Overview

Thank you for purchasing the FiberLyte fiber-coupled laser diode module. It integrates a fibre-coupled laser diode and drive electronics designed by Global Laser.

As light is emitted externally from the fiber end-face, the beam can be positioned separately from the drive electronics. This allows you to install a reliable laser source in hazardous environments where interference such as heat or static would otherwise cause damage to the drive electronics. In the case of hazardous environments, you might consider installing the FiberLyte on a control board which may be temperature- and humidity-controlled to improve the reliability of the diode and extend its lifetime.

A PWM modulation input allows you to drive your laser using a TTL digital voltage signal. You can then change the mark-to-space ratio to control the mean intensity of the output beam, modulate the laser with coded information, or synchronise the laser with an external measurement device such as a machine vision camera.

Available in wavelengths from 405 to 1550nm and powers from 2 to 100mW, the FiberLyte is a high performance and flexible solution to many industrial problems in materials processing, telecommunications, spectroscopy, medical (patient) alignment, and more.

We also offer customised solutions, so please contact us for a FibreLyte outside of this remit.

If you have any queries or require help when using the FiberLyte then please email us on [sales@globallasertech.com](mailto:sales@globallasertech.com) or contact your local representative.



# Handling Optical Fiber

Optical fiber is made of delicate glass or plastic that is susceptible to degradation and damage due to stress. The integrity of the light guide is then lost as light leaks from its core.

While a strength member layer and outer jacket protects and strengthens the delicate material inside which light propagates, it is important to follow proper handling procedures when working with optical fibre. These include:

- Avoid excessively bending, tangling or twisting the fiber. The bend radius should be no smaller than 6.5-30mm depending on fiber type.
- Don't place objects on top of the fiber.
- Ensure that the grip of tools used to manoeuvre or hold the fiber is loose, and that the tool has smooth & soft surfaces.
- Avoid laying the fibre on the floor to avoid it being stepped on.
- Keep the fiber away from sharp edges.
- Clean surfaces, bins or receptacles that come into contact with the fibre end face to avoid particulate contamination.

## Product Operation

### A. Continuous Wave (CW) Mode

The FiberLyte can continuously emit laser radiation without modulation or gating.

- Attach the 4-way JST cable to the socket on the back of the laser module (See drawing A)
- Connect the red, black, yellow, and blue leads as in the table below. If you have purchased a DNI (digital non-inverted) model, connect the yellow lead to Vsupply. If you have purchased a DI model (digital inverted) model connect the yellow lead to 0 volts.

Pin	Lead	FiberLyte PWM Green & Blue Versions	FiberLyte PWM Red & IR Versions
1	Red	+10 to 12 Vdc	+5 Vdc $\pm$ 250mV
2	Black	0 Vdc	0 Vdc
3	Yellow (DNI)	Supply	Supply
	Yellow (DI)	0 Volts	0 Volts
4	Blue	V supply if not using as enable switch	V supply if not using as enable switch

## B. TTL Mode

The FiberLyte PWM can be gated on and off, or pulse-width modulated at TTL voltage levels via the yellow control lead. If a low duty is used, the laser spot may not be entirely visible.

- Connect the red, black, and blue leads as in the table below
- Connect the yellow lead to your TTL signal generator
  - The standard version (DNI) uses an input signal of  $< 0.4 \text{ V} = \text{OFF}$  and  $> 2 \text{ V} = \text{ON}$ , and vice versa for DI
  - The rise time is  $0.5\mu\text{s}$  (typical)

Pin	Lead	FiberLyte PWM Green & Blue Versions	FiberLyte PWM Red & IR Versions
1	Red	+10 to 12 Vdc	+5 Vdc $\pm$ 250mV
2	Black	0 Vdc	0 Vdc
3	Yellow	Input TTL Signal	Input TTL Signal
4	Blue	V supply if not using as enable switch	V supply if not using as enable switch

### Blue Lead (Enable Switch)

An ON/OFF switch function is available via the blue lead. This function is typically used in laser safety systems as a safety interlock or enable switch.

- Apply 0V to switch the laser OFF
- Apply V Supply to switch the laser ON.

A TTL switch can also be utilised via the blue lead (TTL High = on and TTL Low = off). The maximum frequency is typically 100 Hz.

If you do not use the blue lead as an enable switch then connect the blue lead to the V Supply. Otherwise, the laser will remain OFF.

The enable function can also be used as a remote interlock by integrating the 4th pin with a door switch or a micro switch on a safety guard. As the laser only enables when TTL logic level is HIGH your switch can be placed between pin 4 and a +5 V Supply. This can be the same +5 V Supply used to power the laser via pin 1 (ensuring a common ground @ 0 V) or a separate +5 V Supply (must be grounded via pin 2 ensuring a common ground @ 0V).

# Mounting & Heatsinking

The lifetime and stability of your laser can be optimised when mounted on a suitable heat sink. This allows the case temperature to be kept within its specified range. Failure to properly heat sink your laser device could result in shortened lifetime or failure of the diode. As a general guideline, the lifetime of a laser diode decreases by a factor of two (approx.) for every 10°C increase in operating temperature.

Unscrewing the front of FiberLyte reveals a M12x1 threaded front barrel which can be screwed into any matching thread or mounted in a bulkhead utilising the supplied M12x1 nut.

There are three mounting clamps available for the FiberLyte: heavy duty clamp (with/without magnetic base), swivel clamp, and pillow block bearing mount.

## **Mounting the FiberLyte in the Heavy Duty Clamp (See drawing B)**

1. Secure the clamp to a surface. There are two methods:
  - a. Screw an M5 stud to the bottom of the base, or
  - b. Remove the base by removing 2 x grub screw B with the supplied Allen key, then thread an M5 cap screw through the top of the base. Then re-attach the base to the body of the clamp.
2. Loosen Allen screw A with the supplied Allen key
3. Slide your laser into the mounting hole and then tighten Allen screw A
4. Loosen grub screw A
5. Adjust the vertical angle of your laser and then tighten grub screw A
6. Loosen 2 x grub screw B. This will allow the main body of the mount to be rotated independently of the base
7. Adjust the horizontal angle of your laser and then tighten 2 x grub screw B

## **Mounting the FiberLyte in the Heavy Duty Clamp with Magnetic Base (See drawing B & C)**

1. Secure the magnetic base to the Heavy Duty Clamp
  - a. Screw the stud on the top of the magnetic base into the centre hole at the bottom of the Heavy Duty Clamp
2. Remove the keeper from the magnetic base and place on a ferrous surface
3. Loosen Allen screw A with the supplied Allen key
4. Slide your laser into the mounting hole and then tighten Allen screw A
5. Loosen grub screw A
6. Adjust the vertical angle of your laser and then tighten grub screw A
7. Loosen 2 x grub screw B. This will allow the main body of the mount to be rotated independently of the base
8. Adjust the horizontal angle of your laser and then tighten 2 x grub screw B

## **Mounting the FiberLyte in the Swivel Mounting Clamp (See drawing D)**

1. Secure the mounting base to a surface

- a. You can use 2 x Ø9 mm slots, 4 x Ø4.5 mm holes, and/or 2 x Ø3.5 mm countersunk holes to achieve this. If mounting via Ø3.5mm countersunk holes, the swivel bracket must be removed from the base and then reattached after mounting.
2. Loosen Allen screw A (M3)
3. Slide your laser into the mounting hole and then tighten Allen screw A
4. Loosen Allen screw B (M5)
5. Adjust tilt angle and then tighten Allen screw B
6. Loosen 2 x M4 screws attaching swivel bracket to base
7. Adjust swivel angle and then tighten 2 x M4 screws remains with the user.

### Mounting the FiberLyte in the Pillow Block Bearing Mount (See Drawing E)

1. Secure the mount to your workbench or surface using the 20 x 11 mm oval slots in the base
2. Unscrew the M6 or M8 socket head screws to remove the clamp from the base
3. Separate the black mounting cylinder from the spherical rolling element
4. Insert your laser into the mounting cylinder
5. Replace both halves of the spherical rolling element around the cylinder and hold in place
6. Position the spherical rolling element and mounting cylinder in the curved section of the clamp and hold in place
7. Replace the other half of the clamp and hold in place
8. Screw the M6 or M8 socket head screws through the clamp and into the base
9. Manually adjust the direction of your laser

## Safety & Classification

These modules are intended for incorporation into customer equipment. They are classified in accordance with IEC60825-1 2014, which should be consulted prior to designing or using any laser product. The following labels are supplied for attachment to the customer’s equipment, but responsibility for compliance with the standard remains with the user.

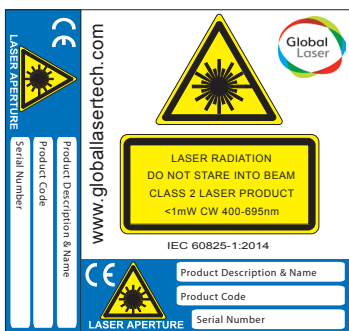

Class 2 Laser Label

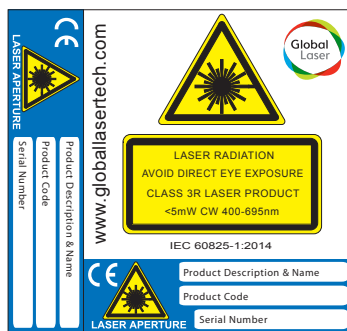

Class 3R Laser Label

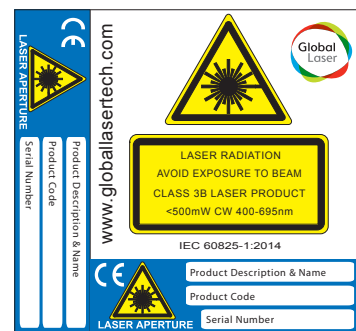

Class 3B Laser Label

# Warranty & Repair

The FiberLyte is supplied with a 12 month parts and labour warranty. Our manufacturing operations are certified to ISO9001.

If your product develops a fault within 12 months from the date of purchase Global Laser will repair/replace your product. If you wish to return a faulty product then please contact your local representative or Global Laser to obtain a RMA code (Return Material Authorisation). Then package your product carefully, including a note of your RMA code, and return to the address below:

Global Laser Ltd  
Unit 9-10  
Roseheyworth Business Park  
Abertillery  
Gwent, NP13 1SP  
United Kingdom

## Mechanical Dimensions

### A) Acculase PWM

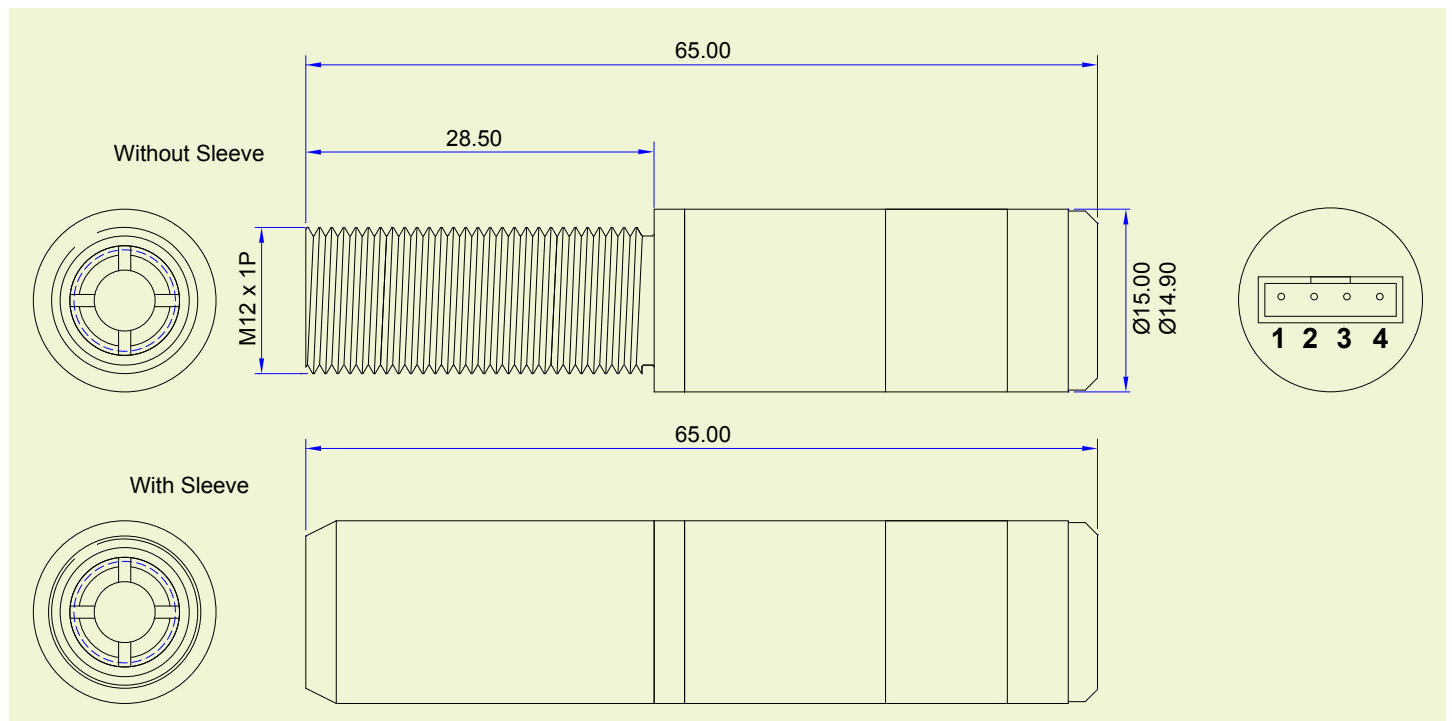

### B) Heavy Duty Mounting Clamp

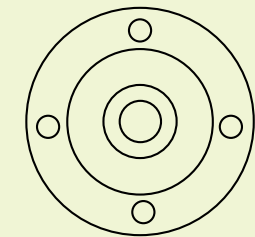
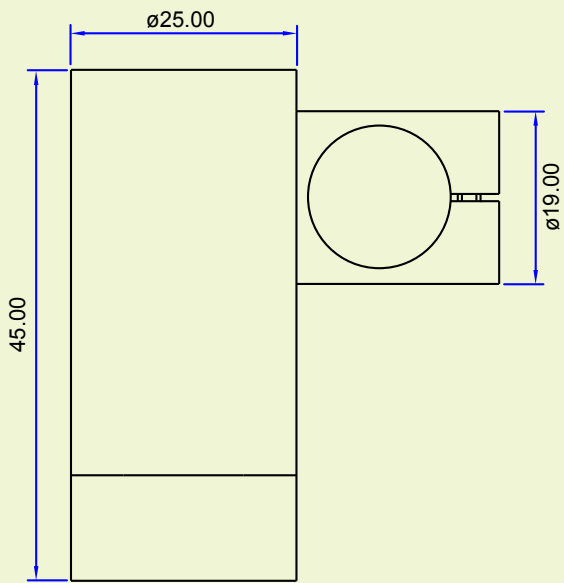

M5 Mounting hole on base

### C) Magnetic Base

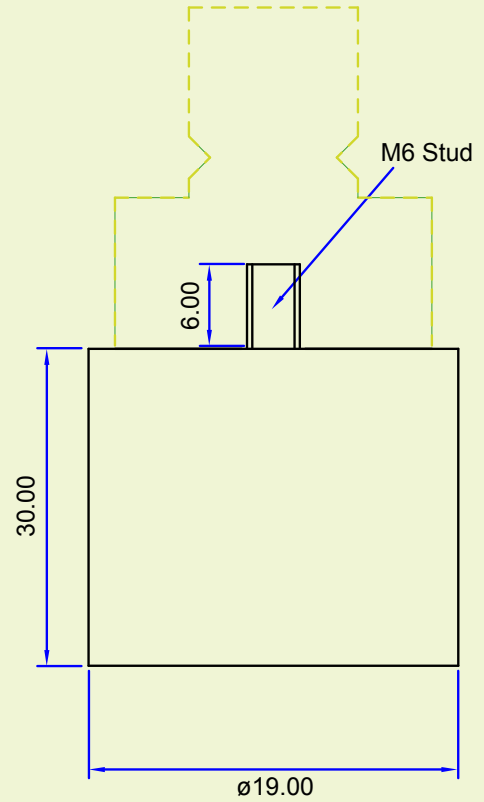

### D) Swivel Mounting Clamp

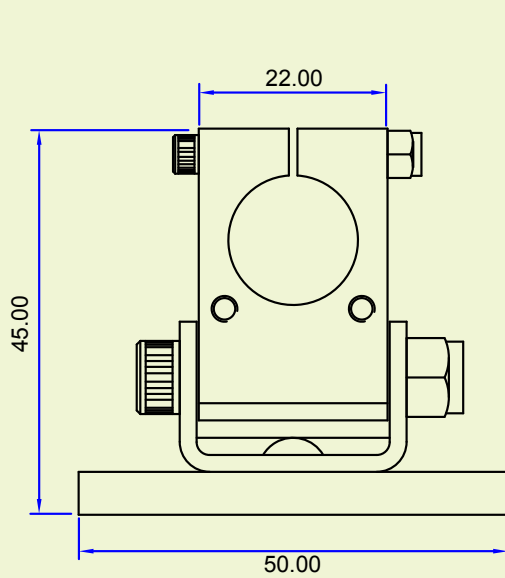

Mounting hole on base 4 x 4.5mm

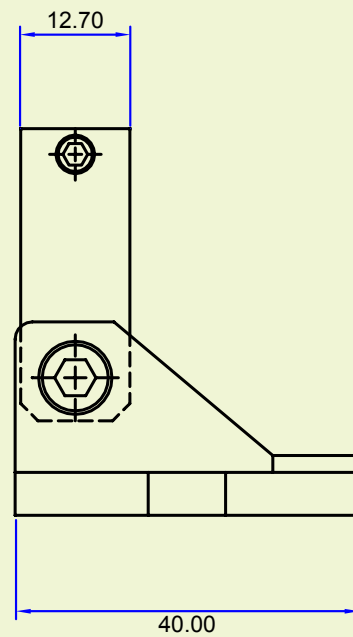

## E) Pillow Block Bearing Clamp

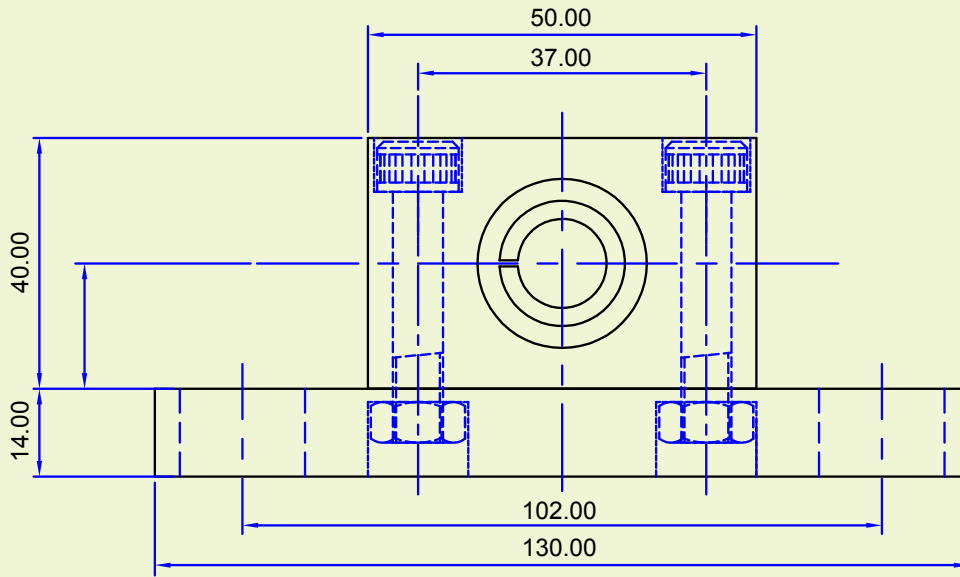

Please Note: Global Laser reserve the right to change descriptions and specifications without notice.



9090-02-137 Rev 1 08/11/2019

T: +44 (0)1495 212213  
F: +44 (0)1495 214004  
E: [sales@globalasertech.com](mailto:sales@globalasertech.com)  
[www.globalasertech.com](http://www.globalasertech.com)

Global Laser Ltd  
Units 9-10  
Roseheyworth Business Park  
Abertillery, Gwent NP13 1SP UK